

Offsets

XY Workpiece

Work Coordinate Offsets (WCS) or Datums

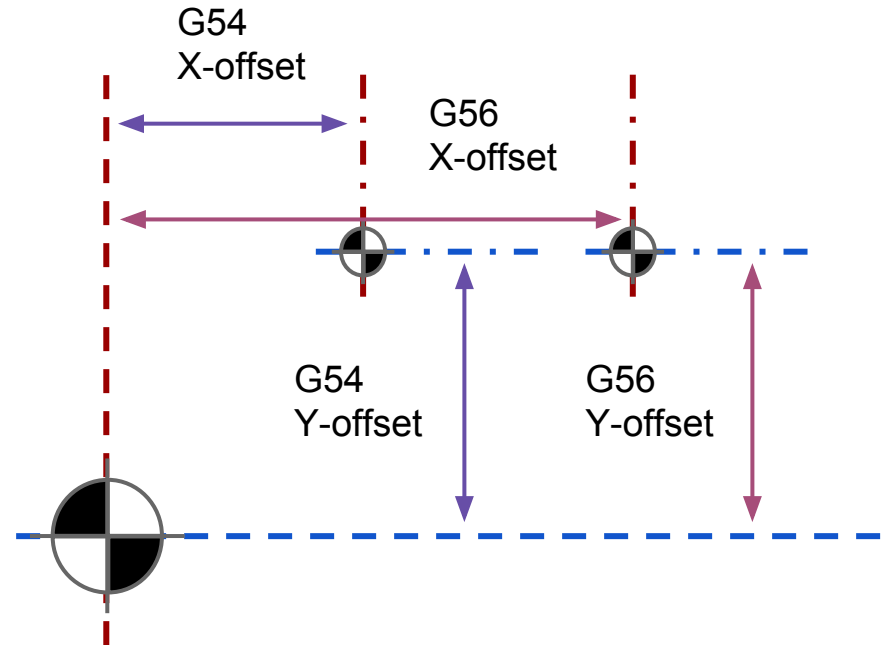
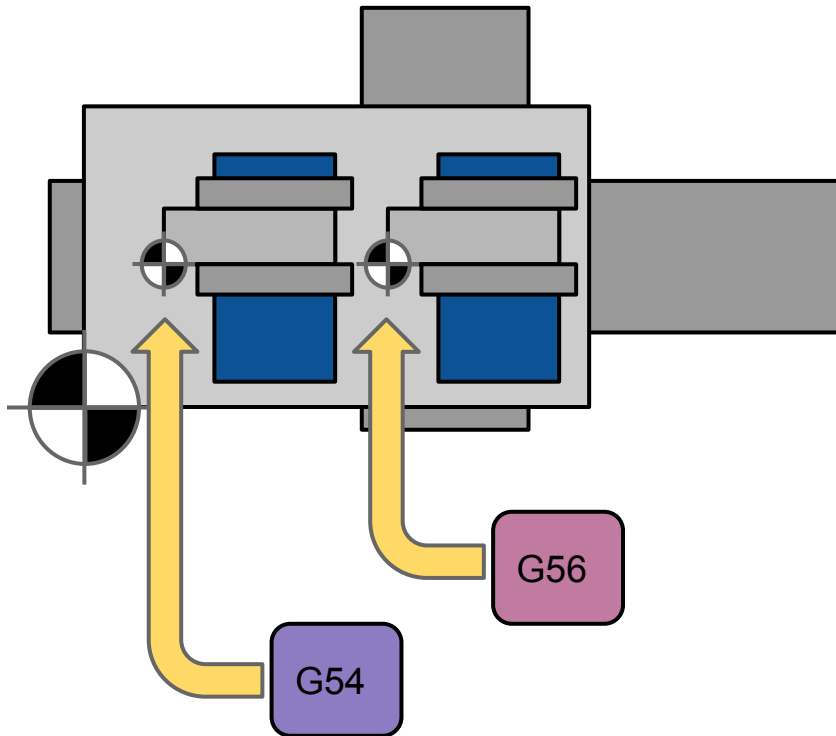

Offset	X-offset	Y-offset
Machine Zero	0	0
G54	-15.65	-17.00
G56	-27.97	-17.00

Line Syntax

“Move to (1.5, -2.0) at 10 units / min”

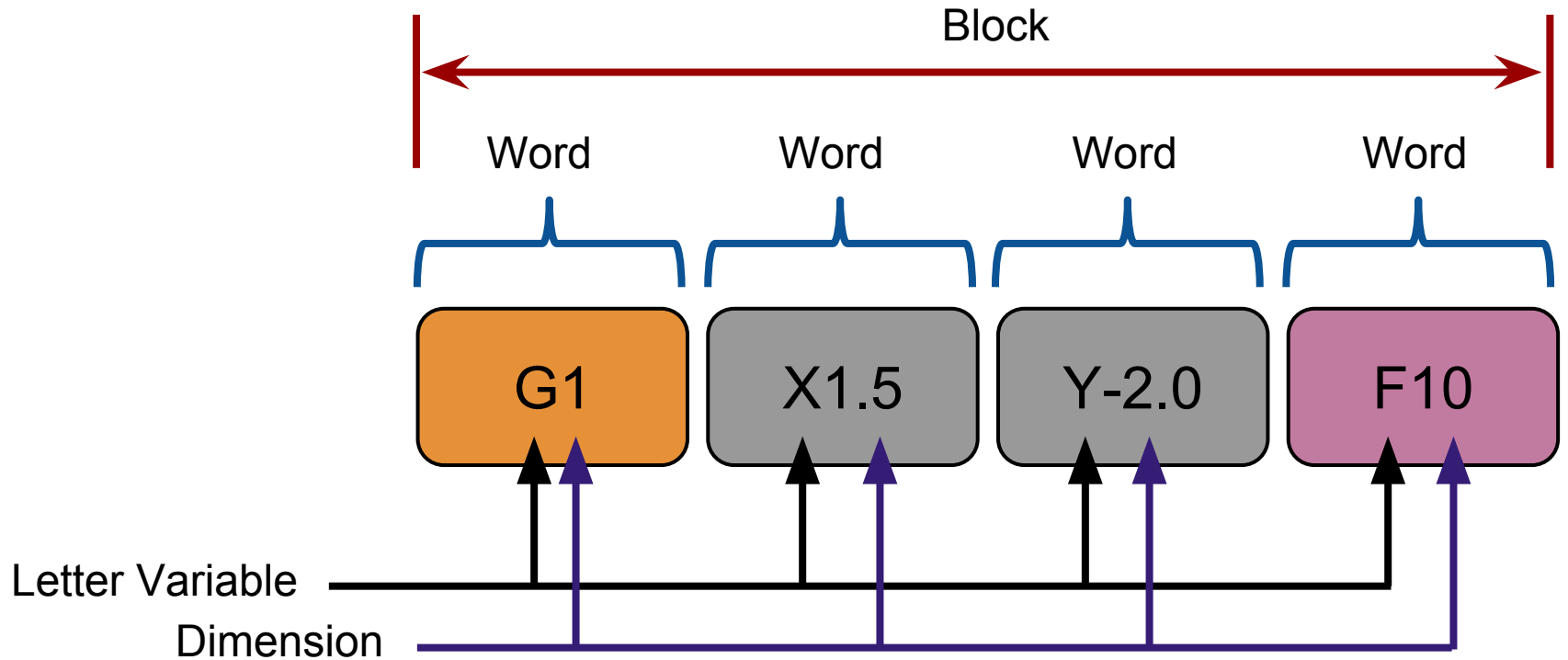

Workbook: Exercise 3

Canned Cycle

Basic Drill/Bore

G81 - Basic Drill

- Hole Location, (X,Y)
- Rapid Height
- Retract, R
- Depth, Z



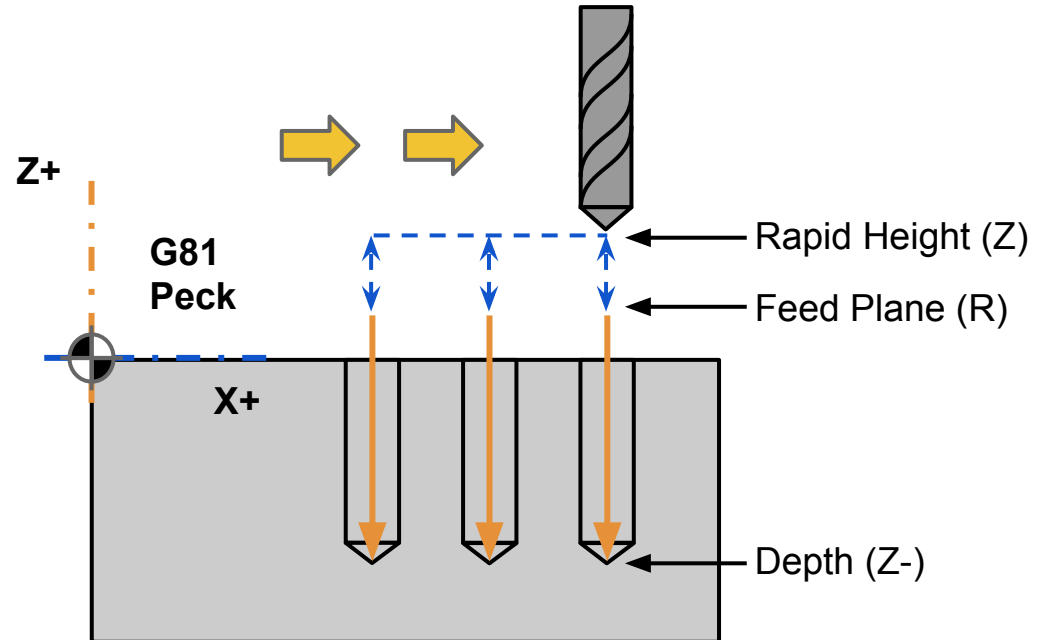

Ex. Thin sheet metal





Syntax: **G81 R2 Z-10**

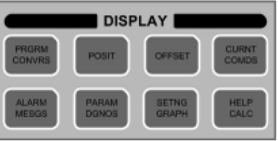
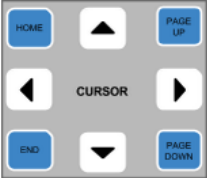

Excerpt Haas Student Handbook

Graphics Mode

Emergency Stop	
Function Keys	
Display Keys	
Cursor Keys	
Jog Keys	

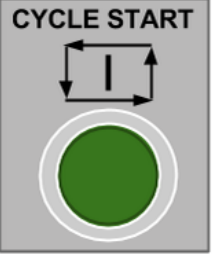
1.	Press MEM [Mode Key]	
2.	Press Setng/Graph Twice [Display Key]	
3.	Press Single Block [Mode Key]	
4.	[Optional] Press Select Program [Mode Key] <ul style="list-style-type: none"> Use this if program has not been loaded by USB Program should show up in right window 	
5.	Cycle Start through each line of code <ul style="list-style-type: none"> Check the graphic if code is performing properly To turn off Single block, press Single block again 	
6.	If Graphic is not screen press F2 to Zoom <ul style="list-style-type: none"> Use Right and Left [Cursor] keys to find in window Use Page Up and Page Down [Cursor] keys to zoom in and out Write/Enter when done Cycle Start to re-plot 	